



HENAN DEJUN INDUSTRIAL CO., LTD

E-mail: info@dejunindustry.com

Cell Phone: +86 137 2144 8067

WhatsApp: +86 137 2144 8067

Wechat: +86 137 2144 8067

Address: Room 1604 No. 4 Building, 9th Street East Cross South Second Road
North, Free Trade Zone, Zhengzhou City, Henan Province, China



Henan Dejun Industrial Co.,Ltd



本产品目录中所登载的产品，均按其使用目的，依照相关法规、规格所规定的功能及性能进行设计。用户在使用过程中，如果使之安装于机器设备中，或其他预料不到的情况下使用，而造成产品性能、功能的下降，或因不可预料的使用而引发的事故，本公司将不承担任何责任。如属特殊用途下使用时，请事先与本公司技术部门联系确认。

本资料为中英文对照版本，如有含义冲突或不明确时，以中文为准。

由于公司坚持在产品开发中不断改进的原则，因此产品的规格可能有所变更，恕不另行通知。

The products entered in this catalog of products are all designed according to their application purposes, in compliance with functions and performances stipulated in related legal regulations and specifications. Our Company shall undertake no responsibility at all for any deterioration of product performances or functions due to user assembly of them in machines and equipments, or application of them under other unexpected situations during use or for any accidents arising from unexpected use.

Please contact technical department of our Company for confirmation in advance when application for special purposes is required.

This direction made of in Chinese and English, in event of conflicts or uncertainty of meaning, the Chinese version shall prevail.

For modification of product specification subjects to continuous betterment in development of various products, no notice will be given separately.

Henan Dejun Industrial Co.,Ltd

环链电动葫芦 ELECTRIC CHAIN HOIST



公 | 司 | 简 | 介 Company Profile

Henan Dejun Industrial Co., Ltd, is a comprehensive industrial company integrating design, production, sales, installs and services a complete line of overhead material handling equipment. The company passes ISO9001 international quality system certification, and gains the international certificates of CE, SGS, and BV, etc.

Our customers distribute throughout the Southeast Asia, Russia, East Europe, the Middle East, Africa and other areas, the products are welcomed by all customers.

The company mainly produces all kinds of overhead crane, gantry crane, electric hoist, electric winch, lifting platform and crane accessories. Dejun has a precision machining team familiar with the industry standard, machining and inspection equipment made in Japan and Europe and America, can provide technical advice and professional and sound whole-process service for customers and is committed to creating unique value for customers with sophisticated equipment and technology.

Dejun Crane has the independent import-export qualification. The crane machinery have exported to more than 60 countries, including the United Kingdom, Sweden, Russia, the United States, Canada, New Zealand, Zambia, Ethiopia, Egypt, UAE, Tajikistan, Thailand, Korea, the Philippines, Indonesia, Bangladesh, Mexico, Brazil, Peru, etc.



目录 CONTENTS

产品编码, 吊钩及链条规格 Products code, hook & chain specifications	01
产品构造图解 Product structure	02
500kg-5t 挂钩式 500kg-5t Fixed type	03
500kg-5t 电动小车运行式 500kg-5t Electric trolley type	05
500kg-5t 手动小车运行式 500kg-5t Manual trolley type	07
7.5t 电动小车运行式 7.5t Electric trolley type	08
10t 挂钩式 10t Fixed	09
10t 电动小车运行式 10t Electric trolley type	09
15t-25t 电动小车运行式 15t-25t Electric trolley type	10
30/35t 固定式 30/35t Fixed type	11
500kg-10t 低净空型 500kg-10t Low-headroom type	12
电动小车 Electric Trolley	14
手动小车 Manual Trolley	15
端梁电机 Girder Motor	16
葫芦配件 Hoist accessories	17
工程案例 Customers	18

产品代码 Products Code

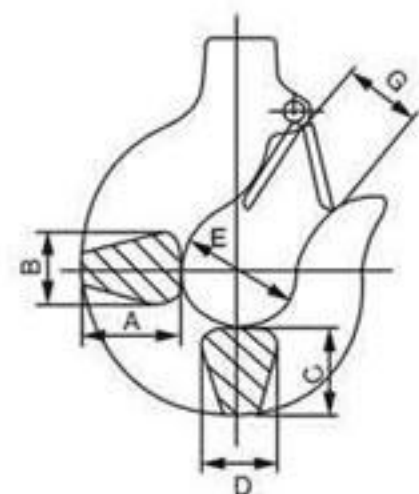
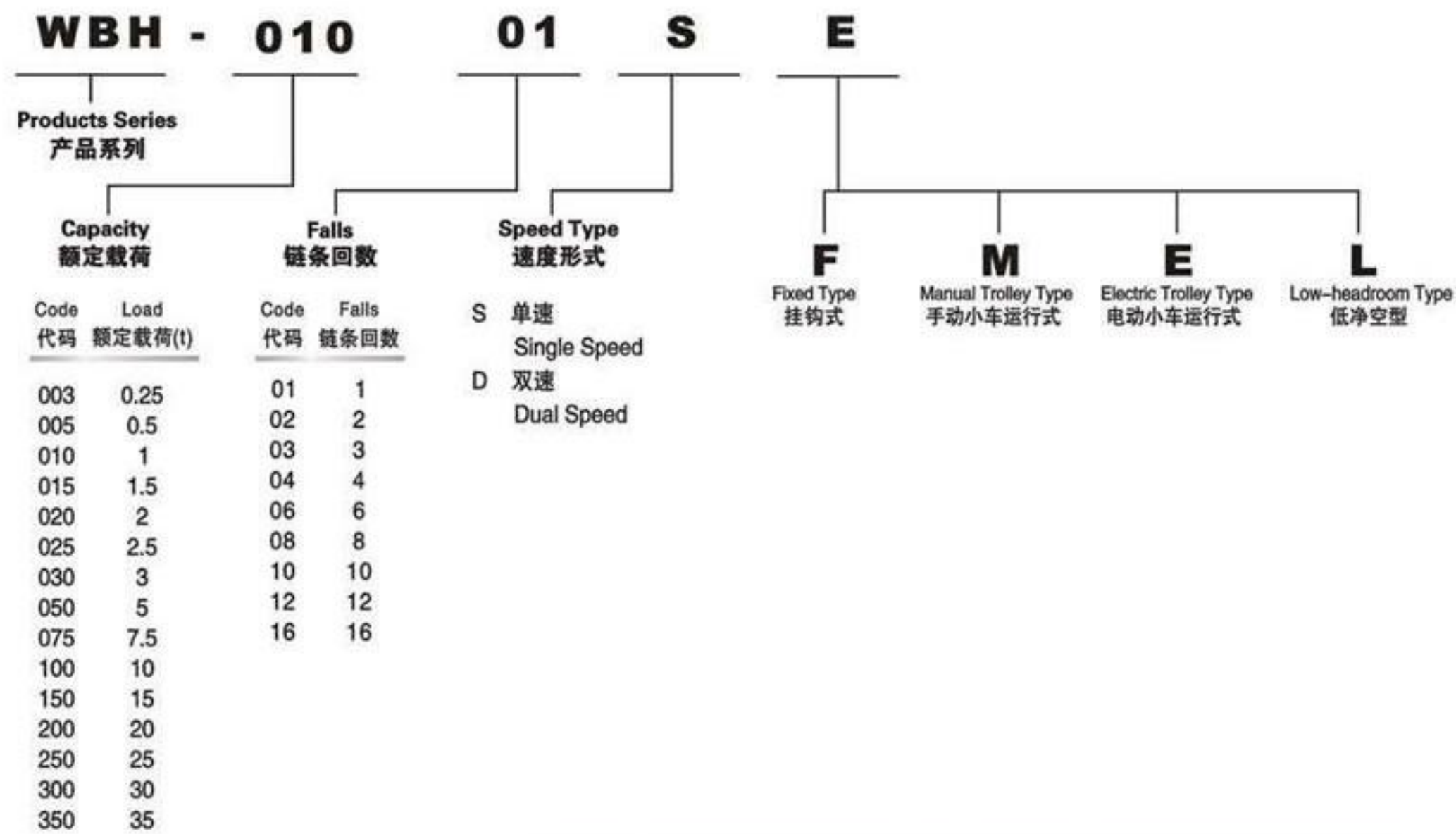

Hook 吊钩

Type 机型	Load 负荷(t)	T	B	A	B	C	D	E	G
WBH	0.3, 0.5	T	B	27	18	25	17	35	28
	1	T	B	34	24	30	24	42	32
	2	T	B	46	29	39	30	49	40
	3	T	B	56	35	49	34	59	48
	5	T	B	67	43	57	44	60	48
	7.5	T	B	82	55	80	48	85	80
	10	T	B	82	55	80	48	85	80
	15	T	B	110	78	120	80	120	96
	20, 25	T	B	142	95	155	98	150	115
	30	T	B	160	130	150	130	140	95
35	T	B	195	150	160	150	160	110	

T-top hook/B-load hook T-上吊钩/B-下吊钩

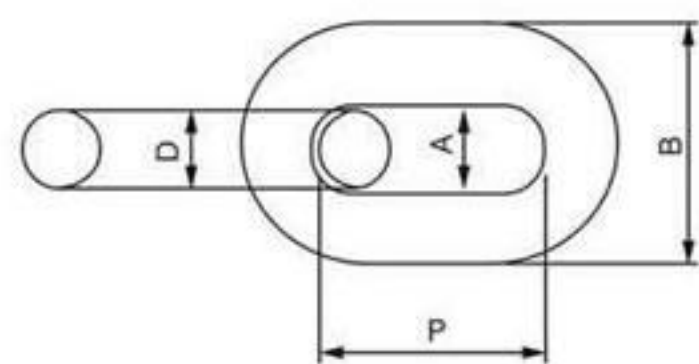

Chain 链条

Applicable Type 使用机型	Diameter 直径(mm)D	Inside Length 节距(mm)P	Inside Width 内宽(mm)A	Outside Width 外宽(mm)B	Work Load 工作负荷(kg)	Guaranteed Load 保证负荷(kN)	Break Load 最大破断负荷(kN)
WBH-00301	6.3	19	7.9	22	1120	27	47
WBH-00501	6.3	19	7.9	22	1120	27	47
WBH-01001	7.1	21	8.9	25	1600	37	61.6
WBH-02002	7.1	21	8.9	25	1600	37	61.6
WBH-03003	7.1	21	8.9	25	1600	37	61.6
WBH-01501	10.0	30	12.5	35	3200	76	125
WBH-02001	10.0	30	12.5	35	3200	76	125
WBH-03002	10.0	30	12.5	35	3200	76	125
WBH-02501	11.2	34	14	37.5	3800	92	154
WBH-03001	11.2	34	14	37.5	3800	92	154
WBH-05002	11.2	34	14	37.5	3800	92	154
WBH-07503	11.2	34	14	37.5	3800	92	154
WBH-10004	11.2	34	14	37.5	3800	92	154
WBH-15006	11.2	34	14	37.5	3800	92	154
WBH-20008	11.2	34	14	37.5	3800	92	154
WBH-25010	11.2	34	14	37.5	3800	92	154
WBH-30012	11.2	34	14	37.5	3800	92	154
WBH-35016	11.2	34	14	37.5	3800	92	154

Shell: It is made of light aluminum alloy shell, light but hard. The cooling fin is especially designed to ensure quick heat dissipation with the rate up to 40% and continuous service. The integral enclosed structure is applicable to places like chemical plant and electroplate factory.

外壳: 铝合金外壳, 坚实而质轻。有特殊散热片, 散热快, 可连续使用, 效率达40%。整体密闭式结构, 可使用在化工厂、电镀厂等地方。

Side magnetic braking device: The magnetic force generator is the latest design which is featured for generating magnetic force. It allows instant brake as soon as the electric power is cut off. Thus the braking safety while loading is guaranteed.

旁磁刹车: 最新设计的磁力产生器, 其特性为产磁。可在电源切断的同时刹车, 保证吊重时刹车绝对确保安全。

Limit switch: The limit switch device is installed where the weight is lifted on and off to make the motor to stop automatically so as to prohibit the chains from exceeding for safety.

限位开关: 吊上吊下都有极限开关装置, 使自动停止, 防止链条超出, 确保安全。

Chain: The chain shall adopt the imported FEC G80 ultra heat-treatable aluminum alloy chain. It can be safely used in poor environments such as rain, sea water and chemicals.

链条: 采用进口 FEC G80 超热处理合金钢链条。在雨水、海水、化学品及其他恶劣状况下使用安全无虞。

Hook: It is hot forging with perfect strength that is hard to break. The operation safety of the lower hook is ensured by its 360 degrees rotation and safety flap.

吊钩: 经热锻造, 强度绝佳, 不易断裂。下吊钩可360°旋转, 附安全舌片, 确保操作安全。

Support frame: The loading support frame consists of two steel plates, which is extremely sturdy.

支撑架: 吊重支撑架由两片钢板组合, 非常坚固。

Transformer: 24V/36V transformer device. This device is used to prohibit unexpected accidents caused by electric leakage and guarantees the safe use while raining.

变压器: 24V/36V 变压装置。操作时, 万一漏电, 可防止意外事故发生, 下雨时, 可保证安全使用。

Electromagnetic contactor: Electromagnetic contactor can be used safely under high frequency.

电磁接触器: 高效率电磁接触器。可高频使用, 没有问题。

Inverse phases sequence protecting device: It is the special electrical installation which controls the circuit not to work in case of wiring error in the power supply.

逆相保护装置: 特殊电气装置, 当电源接线错误时, 控制电路无法动作。

Control switch: Waterproof push button is applied. It is light and durable.

按钮开关: 使用防水按钮开关, 轻便耐用。

Standard Accessories: Chain bag(1) Control cable (3m) Push-button switch (1)

标准配件: 链条袋(1个) 控制电缆(3m) 按钮开关(1只)

500kg-5t

挂钩式 Fixed Type

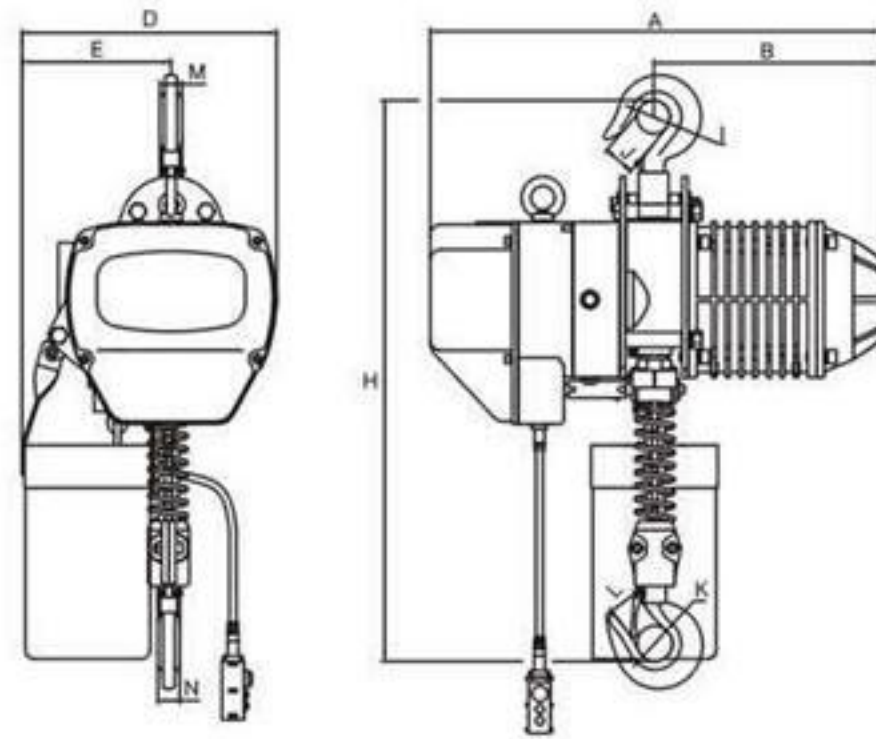

外壳:
外壳轻巧而坚固，散热率高，全密封式设计适合在作业条件较差的环境中使用。

逆相保护装置:
为特殊电器装置，当电源接线错误时，控制电路无法工作。

极限开关:
重物吊上吊下都有极限开关装置，使电机自动停止，以防止链条超出，确保安全。

24V/36V装置:
当在操作时如遇开关漏电，可防止意外事故发生。

制动装置:
此装置可以实现在电源切断时瞬间刹车。

链条袋:
轻巧、美观、耐用。

链条:
采用进口FEC G80超热处理合金钢链条。

Shell:
Light aluminum alloy shell shall be adopted, which is light but hard and fit for the use in the terrible work environment with a high heat dissipation rate and all tightness design.

Inverse phase sequence protecting device:
It is the special electrical installation which controls the circuit not to work in case of wiring error in the power supply.

Limit switch:
The limit switch device is installed where the weight is lifted on and off to make the motor to stop automatically so as to prohibit the chains from exceeding for safety.

24V/36V device:
It is used to prohibit the emergencies from occurring in case of the leakage in the switch.

Side magnetic braking device:
This device shall realize the instant brake in case of the power dump.

Chain bag:
It shall be light, handsome and durable.

Chain:
The chain shall adopt the imported FEC G80 ultra heat-treatable aluminum alloy chain.

Technical Parameters 技术参数

单速 Single Speed

Type 型号	Capacity 额定起重重量(t)	Standard Lifting Height 标准起升高度(m)	Lifting Speed 起升速度(m/min)	起升电机 Lifting Motor					Chain Falls 链条回数	Chain Specification 链条规格	Test Load 试验载荷(t)	Weight 净重(kg)	Weight Added with 1m Higher 每增加1m应加重量(kg)
				Power 功率(kW)	Rotation Speed 转速(r/min)	Phases 相数	Voltage 电压(V)	Frequency 频率(Hz)					
WBH-00501SF	0.5	3	6.8	0.75	1440	3	200-440	50	1	φ6.3	0.625	47	0.81
WBH-01001SF	1	3	6.6	1.5	1440	3	200-440	50	1	φ7.1	1.25	61	1.1
WBH-01002SF	1	3	3.4	0.75	1440	3	200-440	50	2	φ6.3	1.25	52	1.62
WBH-01501SF	1.5	3	8.8	3.0	1440	3	200-440	50	1	φ10.0	1.875	108	2.3
WBH-02001SF	2	3	6.6	3.0	1440	3	200-440	50	1	φ10.0	2.5	115	2.3
WBH-02002SF	2	3	3.3	1.5	1440	3	200-440	50	2	φ7.1	2.5	73	2.2
WBH-02501SF	2.5	3	5.4	3.0	1440	3	200-440	50	1	φ11.2	3.125	116	2.8
WBH-03001SF	3	3	5.4	3.0	1440	3	200-440	50	1	φ11.2	3.75	122	2.8
WBH-03002SF	3	3	4.4	3.0	1440	3	200-440	50	2	φ10.0	3.75	131	4.7
WBH-05002SF	5	3	2.7	3.0	1440	3	200-440	50	2	φ11.2	6.25	151	5.6

双速 Dual Speed

Type 型号	Capacity 额定起重重量(t)	Standard Lifting Height 标准起升高度(m)	Lifting Speed 起升速度(m/min)	起升电机 Lifting Motor					Chain Falls 链条回数	Chain Specification 链条规格	Test Load 试验载荷(t)	Weight 净重(kg)	Weight Added with 1m Higher 每增加1m应加重量(kg)
				Power 功率(kW)	Rotation Speed 转速(r/min)	Phases 相数	Voltage 电压(V)	Frequency 频率(Hz)					
WBH-00501DF	0.5	3	6.9/2.3	0.8/0.27	2890/980	3	200-440	50	1	φ6.3	0.625	47	0.81
WBH-01001DF	1	3	6.9/2.3	1.8/0.6	2890/980	3	200-440	50	1	φ7.1	1.25	61	1.1
WBH-01002DF	1	3	3.5/1.2	0.8/0.27	2890/980	3	200-440	50	2	φ6.3	1.25	52	1.62
WBH-01501DF	1.5	3	8.9/2.9	3.0/1.0	2890/980	3	200-440	50	1	φ10.0	1.875	108	2.3
WBH-02001DF	2	3	6.8/2.3	3.0/1.0	2890/980	3	200-440	50	1	φ10.0	2.5	115	2.3
WBH-02002DF	2	3	3.3/1.1	1.8/0.6	2890/980	3	200-440	50	2	φ7.1	2.5	73	2.2
WBH-02501DF	2.5	3	5.4/1.8	3.0/1.0	2890/980	3	200-440	50	1	φ11.2	3.125	116	2.8
WBH-03001DF	3	3	5.4/1.8	3.0/1.0	2890/980	3	200-440	50	1	φ11.2	3.75	122	2.8
WBH-03002DF	3	3	4.5/1.5	3.0/1.0	2890/980	3	200-440	50	2	φ10.0	3.75	131	4.7
WBH-05002DF	5	3	2.7/0.9	3.0/1.0	2890/980	3	200-440	50	2	φ11.2	6.25	151	5.6

Size Specification 尺寸规格表

单速 Single Speed

Type 型号	H	A	B	D	E	I	J	K	L	M	N
WBH-00501SF	550	460	230	280	160	φ35	25	φ35	25	17	17
WBH-01001SF	650	520	260	300	176	φ40	31	φ40	31	22	22
WBH-01002SF	670	460	230	280	205	φ40	31	φ40	31	22	22
WBH-01501SF	800	615	295	430	265	φ47	40	φ47	38	30	30
WBH-02001SF	800	615	295	430	265	φ47	40	φ47	38	30	30
WBH-02002SF	835	520	260	300	236	φ47	38	φ47	38	30	30
WBH-02501SF	845	615	295	430	265	φ58	47	φ58	47	36	36
WBH-03001SF	845	615	295	430	265	φ58	47	φ58	47	36	36
WBH-03002SF	950	615	295	430	320	φ58	47	φ58	47	36	36
WBH-05002SF	1030	615	295	430	325	φ60	48	φ60	48	43	43

双速 Dual Speed

Type 型号	H	A	B	D	E	I	J	K	L	M	N
WBH-00501DF	550	545	260	280	160	φ35	28	φ35	25	17	17
WBH-01001DF	650	582	280	300	176	φ40	31	φ40	31	22	22
WBH-01002DF	670	545	260	280	205	φ40	31	φ40	31	22	22
WBH-01501DF	800	670	313	430	265	φ47	40	φ47	38	30	30
WBH-02001DF	800	670	313	430	265	φ47	40	φ47	38	30	30
WBH-02002DF	835	582	280	300	236	φ47	38	φ47	38	30	30
WBH-02501DF	845	670	313	430	265	φ58	47	φ58	47	36	36
WBH-03001DF	845	670	313	430	265	φ58	47	φ58	47	36	36
WBH-03002DF	950	670	313	430	320	φ58	47	φ58	47	36	36
WBH-05002DF	1030	670	313	430	325	φ60	48	φ60	48	43	43

500kg-5t

电动小车运行式 Electric Trolley Type

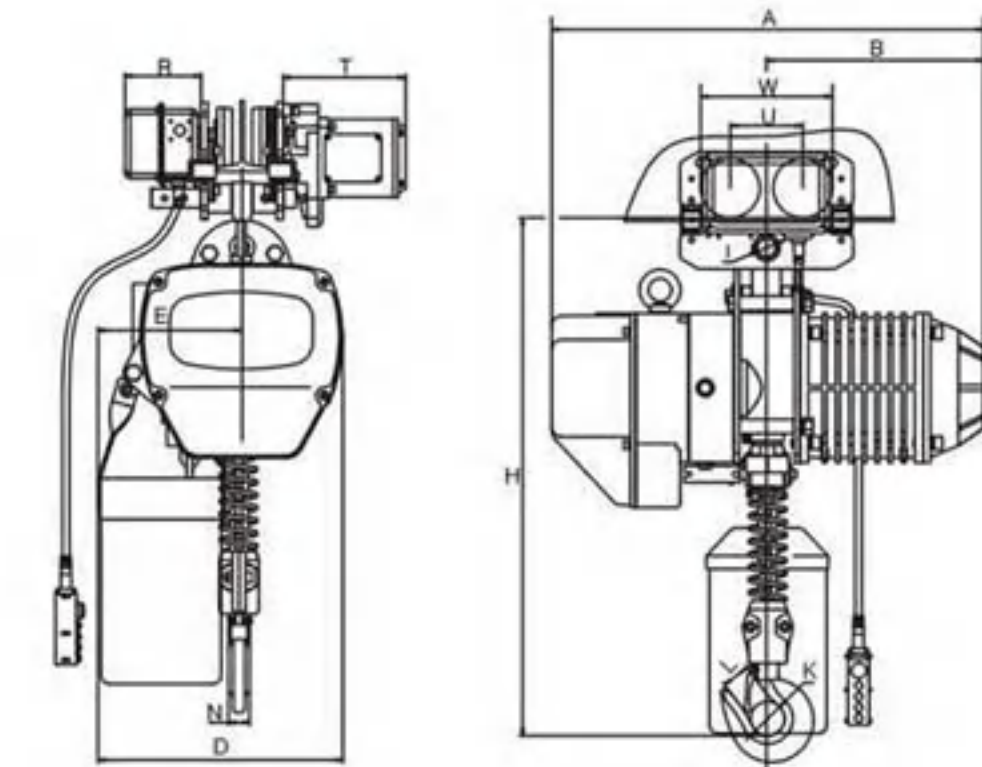

Technical Parameters 技术参数

单速 Single Speed

Type 型号	Capacity 额定起重重量(t)	Standard Lifting Height 标准起升高度(m)	Lifting Speed 起升速度(m/min)	起升电机 Lifting Motor				运行电机 Operation Motor				Chain Falls 链条回条	Chain Specification 链条规格	Test Load 试验载荷(t)	I-Beam 工字钢梁(mm)	Weight 净重(kg)	Weight Added with 1m Higher 吊钩增加重量(kg)		
				Power 功率(kW)	Rotation Speed 转速(r/min)	Phases 相数	Voltage 电压(V)	Frequency 频率(Hz)	Power 功率(kW)	Rotation Speed 转速(r/min)	Operation Speed 运行速度(r/min)							Phases 相数	Voltage 电压(V)
WBH-00501SE	0.5	3	6.8	0.75	1440	3	200-440	50	0.4	1440	11/21	3	200-440	50	1	φ6.1	0.625 58-153	89	0.81
WBH-01001SE	1	3	6.6	1.5	1440	3	200-440	50	0.4	1440	11/21	3	200-440	50	1	φ7.1	1.25 58-153	103	1.1
WBH-01002SE	1	3	3.4	0.75	1440	3	200-440	50	0.4	1440	11/21	3	200-440	50	2	φ6.3	1.25 58-153	101	1.62
WBH-01501SE	1.5	3	8.8	3.0	1440	3	200-440	50	0.4	1440	11/21	3	200-440	50	1	φ10.0	1.875 82-178	157	2.3
WBH-02001SE	2	3	6.6	3.0	1440	3	200-440	50	0.4	1440	11/21	3	200-440	50	1	φ10.0	2.5 82-178	164	2.3
WBH-02002SE	2	3	3.3	1.5	1440	3	200-440	50	0.4	1440	11/21	3	200-440	50	2	φ7.1	2.5 82-178	122	2.2
WBH-02501SE	2.5	3	5.4	3.0	1440	3	200-440	50	0.75	1440	11/21	3	200-440	50	1	φ11.2	3.125 100-178	177	2.8
WBH-03001SE	3	3	5.4	3.0	1440	3	200-440	50	0.75	1440	11/21	3	200-440	50	1	φ11.2	3.75 100-178	183	2.8
WBH-03002SE	3	3	4.4	3.0	1440	3	200-440	50	0.75	1440	11/21	3	200-440	50	2	φ10.0	3.75 100-178	192	4.7
WBH-03003SE	3	3	2.2	1.5	1440	3	200-440	50	0.75	1440	11/21	3	200-440	50	3	φ7.1	3.75 100-178	146	3.5
WBH-05002SE	5	3	2.7	3.0	1440	3	200-440	50	0.75	1440	11/21	3	200-440	50	2	φ11.2	6.25 100-178	234	5.6

双速 Dual Speed

Type 型号	Capacity 额定起重重量(t)	Standard Lifting Height 标准起升高度(m)	Lifting Speed 起升速度(m/min)	起升电机 Lifting Motor				运行电机 Operation Motor				Chain Falls 链条回条	Chain Specification 链条规格	Test Load 试验载荷(t)	I-Beam 工字钢梁(mm)	Weight 净重(kg)	Weight Added with 1m Higher 吊钩增加重量(kg)		
				Power 功率(kW)	Rotation Speed 转速(r/min)	Phases 相数	Voltage 电压(V)	Frequency 频率(Hz)	Power 功率(kW)	Rotation Speed 转速(r/min)	Operation Speed 运行速度(r/min)							Phases 相数	Voltage 电压(V)
WBH-00501DE	0.5	3	6.9/2.3	0.8/0.27	2890/980	3	200-440	50	0.4	1440	11/21	3	200-440	50	1	φ6.1	0.625 58-153	89	0.81
WBH-01001DE	1	3	6.9/2.3	1.8/0.6	2890/980	3	200-440	50	0.4	1440	11/21	3	200-440	50	1	φ7.1	1.25 58-153	116	1.1
WBH-01002DE	1	3	3.5/1.2	0.8/0.27	2890/980	3	200-440	50	0.4	1440	11/21	3	200-440	50	2	φ6.3	1.25 58-153	101	1.62
WBH-01501DE	1.5	3	8.9/2.9	3.0/1.0	2890/980	3	200-440	50	0.4	1440	11/21	3	200-440	50	1	φ10.0	1.875 82-178	193	2.3
WBH-02001DE	2	3	6.8/2.3	3.0/1.0	2890/980	3	200-440	50	0.4	1440	11/21	3	200-440	50	1	φ10.0	2.5 82-178	199	2.3
WBH-02002DE	2	3	3.3/1.1	1.8/0.6	2890/980	3	200-440	50	0.4	1440	11/21	3	200-440	50	2	φ7.1	2.5 82-178	135	2.2
WBH-02501DE	2.5	3	5.4/1.8	3.0/1.0	2890/980	3	200-440	50	0.75	1440	11/21	3	200-440	50	1	φ11.2	3.125 100-178	209	2.8
WBH-03001DE	3	3	5.4/1.8	3.0/1.0	2890/980	3	200-440	50	0.75	1440	11/21	3	200-440	50	1	φ11.2	3.75 100-178	220	2.8
WBH-03002DE	3	3	4.5/1.5	3.0/1.0	2890/980	3	200-440	50	0.75	1440	11/21	3	200-440	50	2	φ10.0	3.75 100-178	229	4.7
WBH-03003DE	3	3	2.4/0.8	1.8/0.6	2890/980	3	200-440	50	0.75	1440	11/21	3	200-440	50	3	φ7.1	3.75 100-178	163	3.5
WBH-05002DE	5	3	2.7/0.9	3.0/1.0	2890/980	3	200-440	50	0.75	1440	11/21	3	200-440	50	2	φ11.2	6.25 100-178	267	5.6

Size Specification 尺寸规格表

单速 Single Speed

Type 型号	H	A	B	D	E	I	K	L	N	W	U	R	T
WBH-00501SE	630	460	230	280	160	φ35	φ35	25	17	206	111	142	231
WBH-01001SE	650	520	260	300	176	φ40	φ40	32	24	206	111	142	231
WBH-01002SE	695	460	230	280	205	φ41	φ40	31	24	206	111	142	231
WBH-01501SE	770	615	295	430	265	φ47	φ47	40	30	237	127	142	231
WBH-02001SE	770	615	295	430	265	φ47	φ47	40	30	237	127	142	231
WBH-02002SE	815	520	260	300	236	φ36	φ47	38	30	237	127	142	231
WBH-02501SE	830	615	295	430	265	φ58	φ58	48	36	265	140	142	231
WBH-03001SE	830	615	295	430	265	φ58	φ58	48	36	265	140	142	231
WBH-03002SE	930	615	295	430	320	φ43	φ58	47	36	265	140	142	231
WBH-03003SE	940	520	260	350	205	φ43	φ58	47	36	265	140	142	231
WBH-05002SE	1015	615	295	430	325	φ54	φ60	48	43	296	156	142	231

双速 Dual Speed

Type 型号	H	A	B	D	E	I	K	L	N	W	U	R	T
WBH-00501DE	630	545	260	280	160	φ35	φ35	25	17	206	111	142	231
WBH-01001DE	650	582	280	300	176	φ40	φ40	32	24	206	111	142	231
WBH-01002DE	695	545	260	280	205	φ41	φ40	31	24	206	111	142	231
WBH-01501DE	770	670	313	430	265	φ47	φ47	40	30	237	127	142	231
WBH-02001DE	770	670	313	430	265	φ47	φ47	40	30	237	127	142	231
WBH-02002DE	815	582	280	300	236	φ36	φ47	38	30	237	127	142	231
WBH-02501DE	830	670	313	430	265	φ58	φ58	47	36	265	140	142	231
WBH-03001DE	830	670	313	430	265	φ58	φ58	47	36	265	140	142	231
WBH-03002DE	930	670	313	430	320	φ43	φ58	47	36	265	140	142	231
WBH-03003DE	940	582	280	350	205	φ43	φ58	47	36	265	140	142	231
WBH-05002DE	1015	670	313	430	325	φ54	φ60	48	43	296	156	142	231



500kg-5t

手动小车运行式
Manual Trolley Type

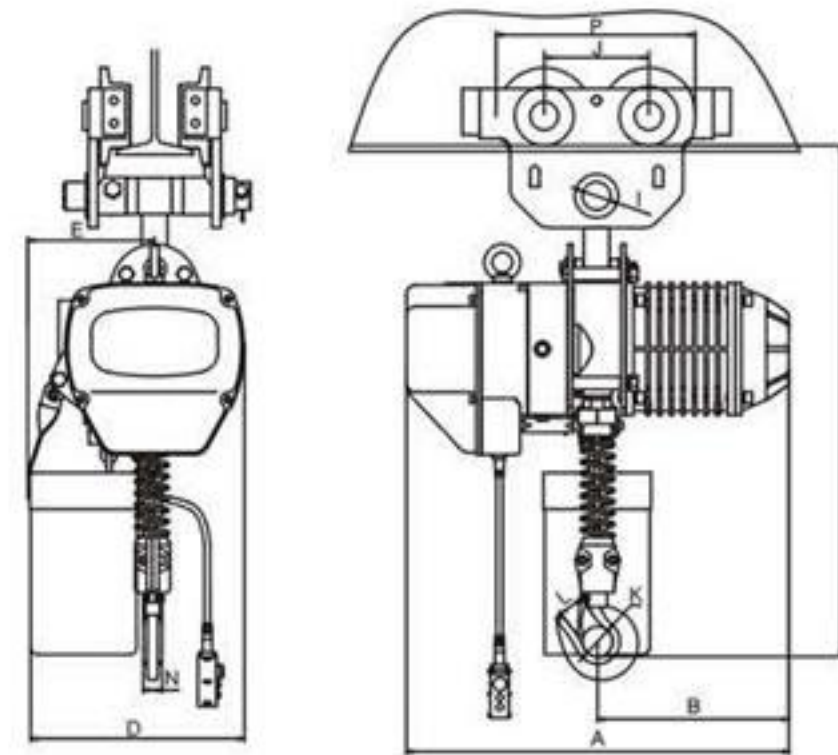

7.5t

电动小车运行式(三回链)
Electric Trolley Type(3 Chain Falls)

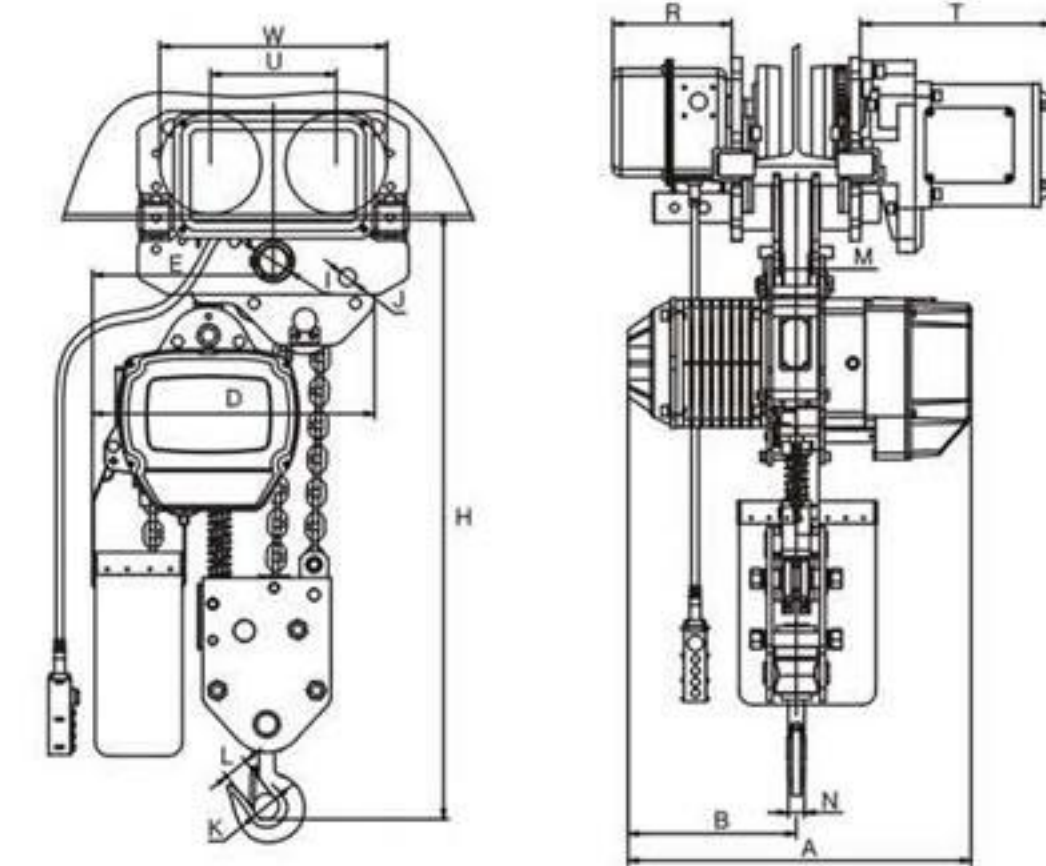

Technical Parameters 技术参数

单速 Single Speed

Type 型号	Capacity 额定起重重量(t)	Standard Lifting Height 标准起升高度(m)	Lifting Speed 起升速度 (m/min)	起升电机 Lifting Motor						Chain Falls 链条回数	Chain Specification 链条规格	Test Load 试验载荷(t)	I-Beam 工字钢梁 (mm)	Weight 净重 (kg)	Weight Added with 1m Higher 每增加1m 应加重量(kg)
				Power 功率(kW)	Rotation Speed 转速(r/min)	Phases 相数	Voltage 电压(V)	Frequency 频率(Hz)							
WBH-00501SM	0.5	3	6.8	0.75	1440	3	200-440	50	1	φ6.3	0.625	68-130	53	0.81	
WBH-01001SM	1	3	6.6	1.5	1440	3	200-440	50	1	φ7.1	1.25	68-130	67	1.1	
WBH-01002SM	1	3	3.4	0.75	1440	3	200-440	50	1	φ7.1	1.25	68-130	67	1.1	
WBH-01501SM	1.5	3	8.8	3.0	1440	3	200-440	50	1	φ10.0	1.875	82-153	118	2.3	
WBH-02001SM	2	3	6.6	3.0	1440	3	200-440	50	1	φ10.0	2.5	82-153	125	2.3	
WBH-02002SM	2	3	3.3	3.0	1440	3	200-440	50	1	φ7.1	2.5	82-153	83	2.3	
WBH-02501SM	2.5	3	5.4	3.0	1440	3	200-440	50	1	φ11.2	3.125	82-153	132	2.8	
WBH-03001SM	3	3	5.4	3.0	1440	3	200-440	50	1	φ11.2	3.75	82-153	138	2.8	
WBH-03002SM	3	3	4.4	3.0	1440	3	200-440	50	2	φ11.2	3.75	82-153	147	4.7	
WBH-03003SM	3	3	2.2	1.5	1440	3	200-440	50	3	φ7.1	3.75	82-153	101	3.4	
WBH-05002SM	5	3	2.7	3.0	1440	3	200-440	50	5	φ11.2	3.75	100-178	181	5.6	

Size Specification 尺寸规格表

单速 Single Speed

Type 型号	H	A	B	D	F	K	L	N	I	J	P
WBH-00501SM	580	460	230	280	160	φ35	28	17	φ28	91	163
WBH-01001SM	635	520	260	300	176	φ40	31	22	φ26	90	164
WBH-01002SM	670	460	230	280	205	φ40	31	22	φ26	90	164
WBH-01501SM	764	615	295	430	265	φ47	38	30	φ31	115	221
WBH-02001SM	764	615	295	430	265	φ47	38	30	φ31	115	221
WBH-02002SM	800	520	260	300	236	φ47	38	30	φ31	115	221
WBH-02501SM	854	615	295	430	265	φ58	47	36	φ36	138	265
WBH-03001SM	854	615	295	430	265	φ58	47	36	φ36	138	265
WBH-03002SM	960	615	295	430	320	φ58	47	36	φ36	138	265
WBH-03003SM	968	520	260	350	205	φ58	47	36	φ36	138	265
WBH-05002SM	1007	615	295	430	325	φ60	48	43	φ43	157	304

Technical Parameters 技术参数

单速/双速 Single Speed/Dual Speed

Type 型号	Capacity 额定起重重量(t)	Standard Lifting Height 标准起升高度(m)	Lifting Speed 起升速度 (m/min)	起升电机 Lifting Motor						运行电机 Operation Motor						Chain Falls 链条回数	Chain Specification 链条规格	Test Load 试验载荷 (t)	I-Beam 工字钢梁 (mm)	Weight 净重 (kg)	Weight Added with 1m Higher 每增加1m 应加重量(kg)
				Power 功率 (kW)	Rotation Speed 转速(r/min)	Phases 相数	Voltage 电压(V)	Frequency 频率(Hz)	Power 功率 (kW)	Rotation Speed 转速(r/min)	Operation Speed 运行速度 (m/min)	Phases 相数	Voltage 电压 (V)	Frequency 频率 (Hz)							
WBH-07503SE	7.5	3	1.8	3.0	1440	3	200-440	50	0.75	1440	11/21	3	200-440	50	3	φ11.2	9.4	100-178	266	8.4	
WBH-07503DE	7.5	3	1.8/0.6	3.0/1.0	2890/980	3	200-440	50	0.75	1440	11/21	3	200-440	50	3	φ11.2	9.4	100-178	305	8.4	

Size Specification 尺寸规格表

单速/双速 Single Speed/Dual Speed

Type 型号	H	A	B	D	E	I	J	K	L	M	N	W	U	R	T
WBH-07503SE	1200	615	295	505	320	φ54	φ31	φ85	80	85	55	295	156	142	231
WBH-07503DE	1200	670	313	505	320	φ54	φ31	φ85	80	85	55	295	156	142	231

10t

挂钩式 Fixed Type

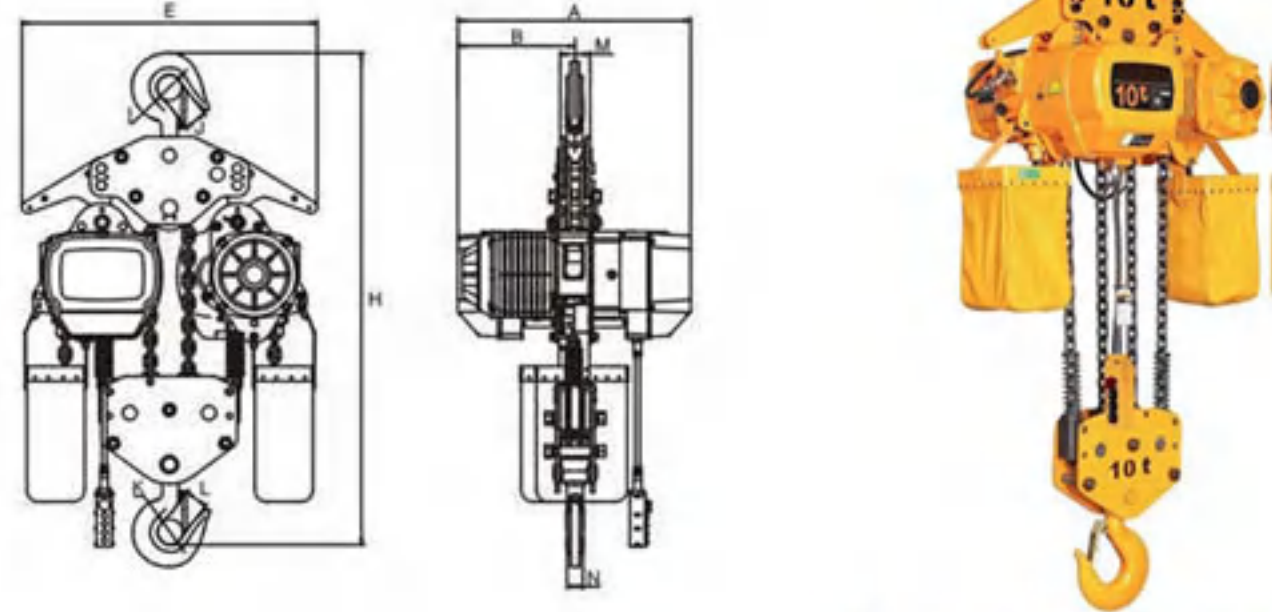

Technical Parameters 技术参数

Type 型号	Capacity 额定起重重量(t)	Standard Lifting Height 标准起升高度(m)	Lifting Speed 起升速度(m/min)	起升电机 Lifting Motor					Chain Falls 链条回数	Chain Specification 链条规格	Test Load 试验载荷(t)	Weight 净重(kg)	Weight Added with 1m Higher 吊程每增加1m 应加重量(kg)
				Power 功率(kW)	Rotation Speed 转速(r/min)	Phases 相数	Voltage 电压(V)	Frequency 频率(Hz)					
WBH-10004SF	10	3	2.7	3.0	1440	3	200-440	50	4	φ11.2	12.5	300	8.4
WBH-10004DF	10	3	2.7/0.9	3.0x2/1.0x2	2890/980	3	200-440	50	4	φ11.2	12.5	300	8.4

单速/双速 Single Speed/Dual Speed

Size Specification 尺寸规格表

Type 型号	H	A	B	D	E	I	J	K	L	M	N
WBH-10004SF	1400	630	315	/	890	φ85	80	φ80	80	104	55
WBH-10004DF	1400	685	352	/	890	φ85	80	φ85	80	104	55

单速/双速 Single Speed/Dual Speed

10t

电动小车运行式 Electric Trolley Type

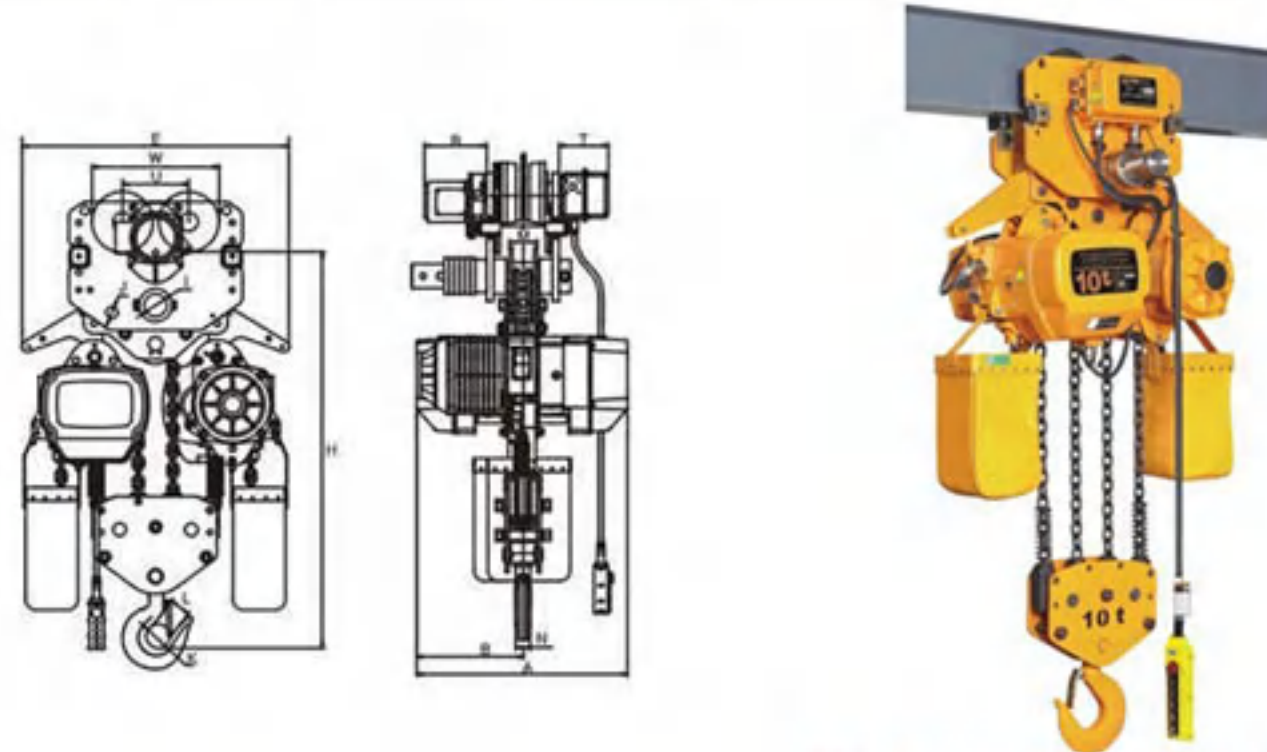

Technical Parameters 技术参数

Type 型号	Capacity 额定起重重量(t)	Standard Lifting Height 标准起升高度(m)	Lifting Speed 起升速度(m/min)	起升电机 Lifting Motor					运行电机 Operation Motor					Chain Falls 链条回数	Chain Specification 链条规格	Test Load 试验载荷(t)	Weight 净重(kg)	I-Beam 工字钢梁(mm)	Weight Added with 1m Higher 吊程每增加1m 应加重量(kg)	
				Power 功率(kW)	Rotation Speed 转速(r/min)	Phases 相数	Voltage 电压(V)	Frequency 频率(Hz)	Power 功率(kW)	Rotation Speed 转速(r/min)	Operation Speed 运行速度(m/min)	Phases 相数	Voltage 电压(V)							Frequency 频率(Hz)
WBH-10004SE	10	3	2.7	3.0	1440	3	200-440	50	0.75	1440	11/21	3	200-440	50	4	φ11.2	12.5	440	150-220	11
WBH-10004DE	10	3	2.7/0.9	3.0x2/1.0x2	2890/980	3	200-440	50	0.75	1440	11/21	3	200-440	50	4	φ11.2	12.5	520	150-220	11

单速/双速 Single Speed/Dual Speed

Size Specification 尺寸规格表

Type 型号	H	A	B	D	E	I	J	K	L	M	N	W	U	R	T
WBH-10004SE	1190	630	315	/	890	φ70	φ36	φ85	80	85	55	366	191	142	231
WBH-10004DE	1190	685	352	/	890	φ70	φ36	φ85	80	85	55	366	191	142	231

单速/双速 Single Speed/Dual Speed

15t-25t

电动小车运行式 Electric Trolley Type

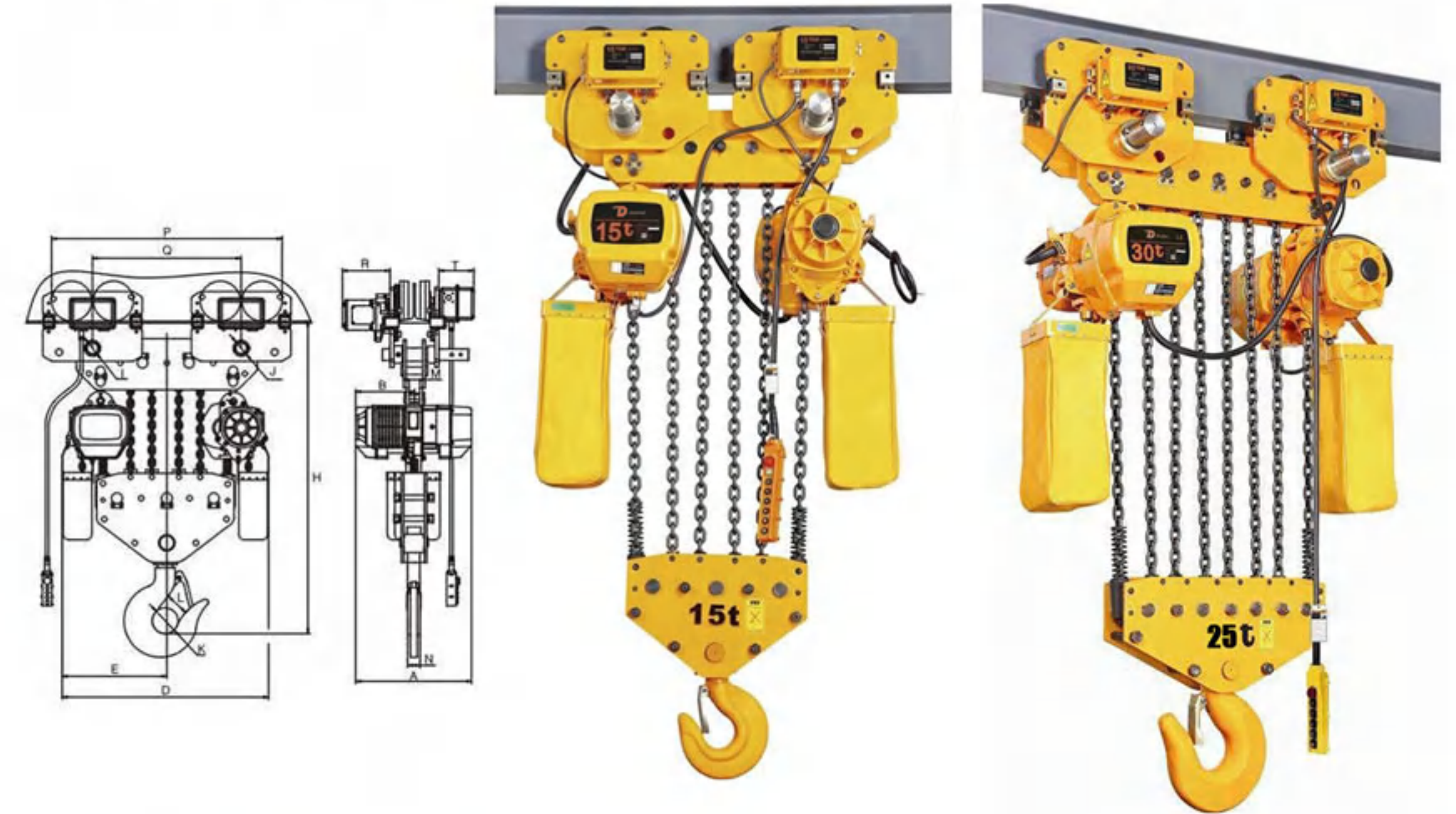

Technical Parameters 技术参数

Type 型号	Capacity 额定起重重量(t)	Standard Lifting Height 标准起升高度(m)	Lifting Speed 起升速度(m/min)	起升电机 Lifting Motor					运行电机 Operation Motor					Chain Falls 链条回数	Chain Specification 链条规格	Test Load 试验载荷(t)	I-Beam 工字钢梁(mm)	Weight 净重(kg)	Weight Added with 1m Higher 吊程每增加1m 应加重量(kg)	
				Power 功率(kW)	Rotation Speed 转速(r/min)	Phases 相数	Voltage 电压(V)	Frequency 频率(Hz)	Power 功率(kW)	Rotation Speed 转速(r/min)	Operation Speed 运行速度(m/min)	Phases 相数	Voltage 电压(V)							Frequency 频率(Hz)
WBH-15006SE	15	3	1.8	3.0x2	1440	3	200-440	50	0.75x2	1440	11/21	3	200-440	50	6	φ11.2	18.75	150-220	400	17
WBH-20008SE	20	3	1.4	3.0x2	1440	3	200-440	50	0.75x2	1440	11/21	3	200-440	50	8	φ11.2	25	150-220	480	22
WBH-25010SE	25	3	1.1	3.0x2	1440	3	200-440	50	0.75x2	1440	11/21	3	200-440	50	10	φ11.2	31.25	150-220	540	28
WBH-15006DE	15	3	1.8/0.6	3.0x2/1.0x2	2890/980	3	200-440	50	0.75x2	2890/980	11/21	3	200-440	50	6	φ11.2	18.75	150-220	480	17
WBH-20008DE	20	3	1.5/0.6	3.0x2/1.0x2	2890/980	3	200-440	50	0.75x2	2890/980	11/21	3	200-440	50	8	φ11.2	25	150-220	560	22
WBH-25010DE	25	3	1.2/0.4	3.0x2/1.0x2	2890/980	3	200-440	50	0.75x2	2890/980	11/21	3	200-440	50	10	φ11.2	31.25	150-220	620	28

单速/双速 Single Speed/Dual Speed

Size Specification 尺寸规格表

Type 型号	H	A	B	D	E	I	J	K	L	M	N	P	Q	R	T
WBH-15006SE	1310	630	315	1070	535	φ54	φ54	φ120	96	88	78	926	560	142	231
WBH-20008SE	1470	630	315	1260	630	φ70	φ70	φ150	115	88	98	1106	740	142	231
WBH-25010SE	1580	630	315	1260	725	φ70	φ70	φ150	115	88	95	1280	830	142	231
WBH-15006DE	1310	685	352	1070	535	φ54	φ54	φ120	96	88	78	926	560	142	231
WBH-20008DE	1470	685	352	1260	630	φ70	φ70	φ150	115	88	98	1106	740	142	231
WBH-25010DE	1580	685	352	1260	725	φ70	φ70	φ150	115	88	95	1280	830	142	231

单速/双速 Single Speed/Dual Speed

30t

固定式 Fixed Type

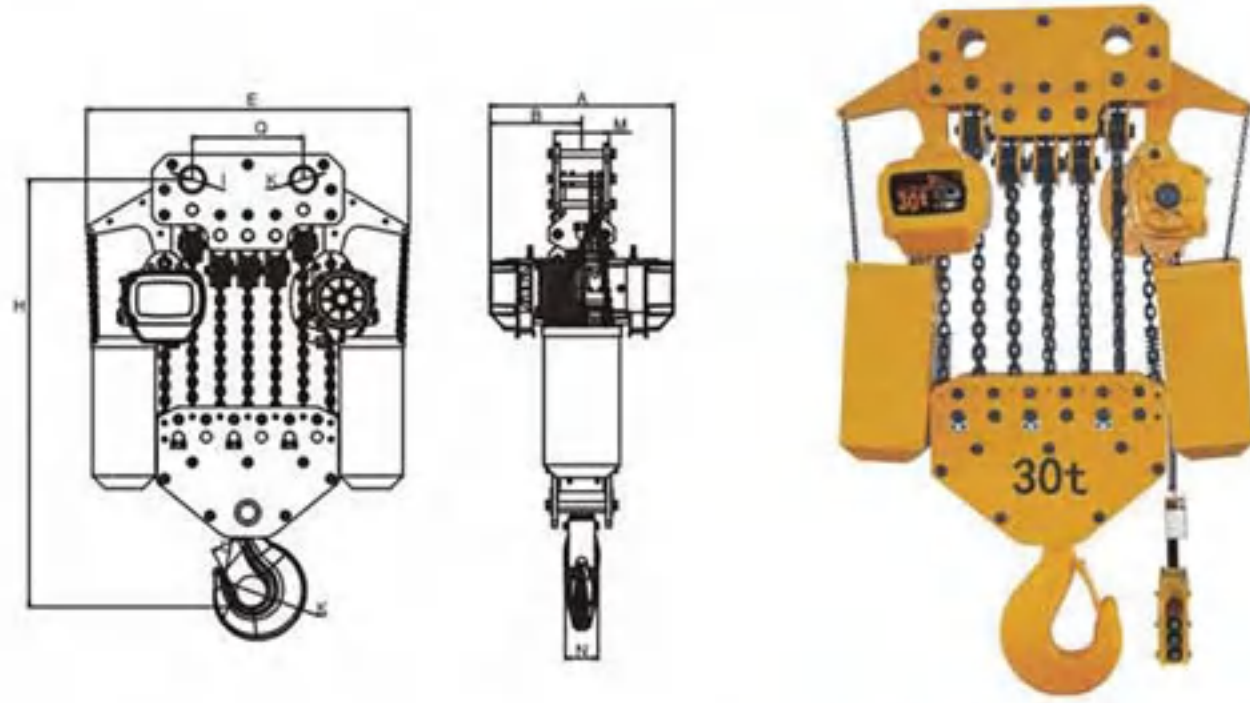

Technical Parameters 技术参数

Type 型号	Capacity 额定起重重量(t)	Standard Lifting Height 标准起升高度(m)	Lifting Speed 起升速度(m/min)	起升电机 Lifting Motor					Chain Falls 链条回数	Chain Specification 链条规格	Test Load 试验载荷(t)	Weight 净重(kg)	Weight Added with 1m Higher 按程每增加1m 应加重量(kg)
				Power 功率(kW)	Rotation Speed 转速(r/min)	Phases 相数	Voltage 电压(V)	Frequency 频率(Hz)					
WBH-30012SF	30	3	0.9	3.0x2	1440	3	200-440	50	12	φ11.2	37.5	1050	31
WBH-30012DF	30	3	1.0/0.3	3.0x2/1.0x2	2890/980	3	200-440	50	12	φ11.2	37.5	1100	31

单速/双速 Single Speed/Dual Speed

Size Specification 尺寸规格表

Type 型号	H	A	B	E	I	J	K	L	Q	M	N
WBH-30012SF	1640	740	315	1300	φ100	φ100	φ140	95	440	217	130
WBH-30012DF	1640	795	352	1300	φ100	φ100	φ140	95	440	217	130

单速/双速 Single Speed/Dual Speed

35t

固定式 Fixed Type

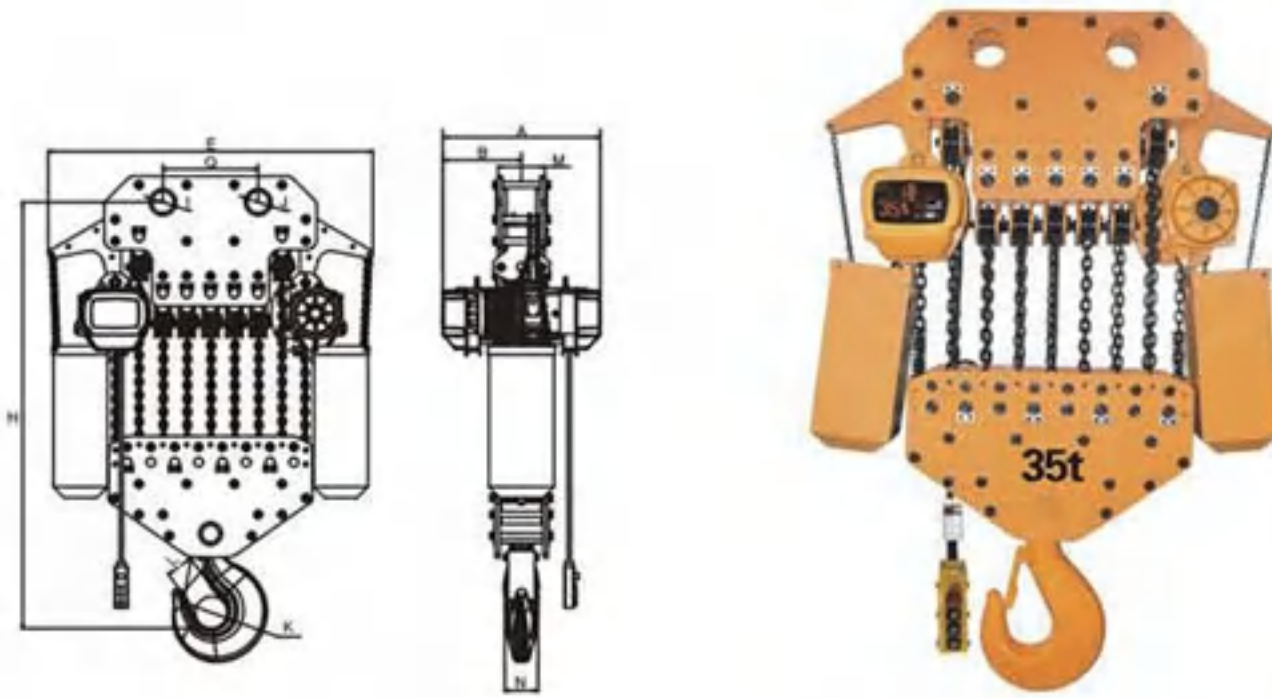

Technical Parameters 技术参数

Type 型号	Capacity 额定起重重量(t)	Standard Lifting Height 标准起升高度(m)	Lifting Speed 起升速度(m/min)	起升电机 Lifting Motor					Chain Falls 链条回数	Chain Specification 链条规格	Test Load 试验载荷(t)	Weight 净重(kg)	Weight Added with 1m Higher 按程每增加1m 应加重量(kg)
				Power 功率(kW)	Rotation Speed 转速(r/min)	Phases 相数	Voltage 电压(V)	Frequency 频率(Hz)					
WBH-35016SF	35	3	0.7	3.0x2	1440	3	200-440	50	16	φ11.2	43.75	1250	44.8
WBH-35016DF	35	3	0.7/0.25	3.0x2/1.0x2	2890/980	3	200-440	50	16	φ11.2	43.75	1310	44.8

单速/双速 Single Speed/Dual Speed

Size Specification 尺寸规格表

Type 型号	H	A	B	E	I	J	K	L	Q	M	N
WBH-35016SF	1790	740	315	1500	φ100	φ100	φ200	140	440	217	150
WBH-35016DF	1790	795	352	1500	φ100	φ100	φ200	140	440	217	150

单速/双速 Single Speed/Dual Speed



500kg-10t

低净空型环链电动葫芦

Low-Headroom Electric Chain Hoist

Product Features:

Vanbon Ultra Low Headroom Electric Chain Hoists are designed for those applications where space is limited. The units provide smooth, quiet trouble free operation in a variety of Class III applications. The units are equipped with the following features:

- FEC G80 ultra heat-treated alloy steel chain which is suitable for rain, sea water and chemical environments.
- Choices of lug mounted push/pull, hand geared or motorized trolley drives geared limit switches for both upper and lower hook travel.
- Standard voltage is 200-440Volt, 3 phase.
- Capacities from 0.5ton through 10 tons.
- Sturdy steel construction
- Direct acting motor brakes

Vanbon低净空环链电动葫芦专为操作空间受限制而设计的机种，可达扬程最大化，并争取较大的操作高度。

具备以下特点：

- 使用FEC G80超热处理合金钢进口链条，适用于雨水，海水以及化学环境中。
- 固定式以及电动运行式，供选择；
- 标配限位开关，急停按钮，起吊更安全；
- 电压区间：200-440V；
- 载重为0.5-10吨。

Technical Parameters 技术参数

Type 型号	Capacity 额定起重重量(t)	Standard Lifting Height 标准起升高度(m)	Lifting Speed 起升速度(m/min)	起升电机 Lifting Motor					运行电机 Operation Motor					Chain Falls 链条回数	Chain Specification 链条规格	Test Load 试验载荷(t)	I-Beam 工字钢梁(mm)	Weight Added with 1m Higher 按程每增加1m 应加重量(kg)	
				Power 功率(kW)	Rotation Speed 转速(r/min)	Phases 相数	Voltage 电压(V)	Frequency 频率(Hz)	Power 功率(kW)	Rotation Speed 转速(r/min)	Operation Speed 运行速度(m/min)	Phases 相数	Voltage 电压(V)						Frequency 频率(Hz)
WBH-00501SL	0.5	3	6.8	0.75	1440	3	200-440	50	0.4	1440	11/21	3	200-440	50	1	φ6.3	0.625	58-153	0.81
WBH-01001SL	1	3	6.6	1.5	1440	3	200-440	50	0.4	1440	11/21	3	200-440	50	1	φ7.1	1.25	58-153	1.1
WBH-01501SL	1.5	3	8.8	3.0	1440	3	200-440	50	0.4	1440	11/21	3	200-440	50	1	φ10.0	1.875	82-178	2.3
WBH-02001SL	2	3	6.6	3.0	1440	3	200-440	50	0.4	1440	11/21	3	200-440	50	1	φ10.0	2.5	82-178	2.3
WBH-02002SL	2	3	3.3	1.5	1440	3	200-440	50	0.4	1440	11/21	3	200-440	50	2	φ7.1	2.5	82-178	2.2
WBH-02501SL	2.5	3	5.4	3.0	1440	3	200-440	50	0.75	1440	11/21	3	200-440	50	1	φ11.2	3.125	100-178	2.8
WBH-03001SL	3	3	5.4	3.0	1440	3	200-440	50	0.75	1440	11/21	3	200-440	50	1	φ11.2	3.75	100-178	2.8
WBH-03002SL	3	3	4.4	3.0	1440	3	200-440	50	0.75	1440	11/21	3	200-440	50	2	φ10.0	3.75	100-178	4.7
WBH-05002SL	5	3	2.7	3.0	1440	3	200-440	50	0.75	1440	11/21	3	200-440	50	2	φ11.2	6.25	100-178	5.6
WBH-07503SL	7.5	3	1.8	3.0	1440	3	200-440	50	0.75	1440	11/21	3	200-440	50	3	φ11.2	9.4	100-178	8.4
WBH-10004SL	10	3	2.7	3.0x2	1440	3	200-440	50	0.75	1440	11/21	3	200-440	50	4	φ11.2	12.5	150-220	11
WBH-00501DL	0.5	3	6.9/2.3	0.8/0.3	2890/980	3	200-440	50	0.4	1440	11/21	3	200-440	50	1	φ6.3	0.625	58-153	0.81
WBH-01001DL	1	3	6.9/2.3	1.8/0.6	2890/980	3	200-440	50	0.4	1440	11/21	3	200-440	50	1	φ7.1	1.25	58-153	1.1
WBH-01501DL	1.5	3	9.0/3.0	3.0/1.0	2890/980	3	200-440	50	0.4	1440	11/21	3	200-440	50	1	φ10.0	1.875	82-178	2.3
WBH-02001DL	2	3	6.9/2.3	3.0/1.0	2890/980	3	200-440	50	0.4	1440	11/21	3	200-440	50	1	φ10.0	2.5	82-178	2.3
WBH-02002DL	2	3	3.4/1.1	1.8/0.6	2890/980	3	200-440	50	0.4	1440	11/21	3	200-440	50	2	φ7.1	2.5	82-178	2.2
WBH-02501DL	2.5	3	5.4/1.8	3.0/1.0	2890/980	3	200-440	50	0.75	1440	11/21	3	200-440	50	1	φ11.2	3.125	100-178	2.8
WBH-03001DL	3	3	5.4/1.8	3.0/1.0	2890/980	3	200-440	50	0.75	1440	11/21	3	200-440	50	1	φ11.2	3.75	100-178	2.8
WBH-03002DL	3	3	4.5/1.5	3.0/1.0	2890/980	3	200-440	50	0.75	1440	11/21	3	200-440	50	2	φ10.0	3.75	100-178	4.7
WBH-05002DL	5	3	2.7/0.9	3.0/1.0	2890/980	3	200-440	50	0.75	1440	11/21	3	200-440	50	2	φ11.2	6.25	100-178	5.6
WBH-07503DL	7.5	3	1.8/0.6	3.0/1.0	2890/980	3	200-440	50	0.75	1440	11/21	3	200-440	50	3	φ11.2	9.4	100-178	8.4
WBH-10004DL	10	3	2.7/0.9	3.0x2/1.0x2	2890/980	3	200-440	50	0.75	1440	11/21	3	200-440	50	4	φ11.2	12.5	150-220	11

单速/双速 Single Speed/Dual Speed

10t 低净空型环链电动葫芦

Low-Headroom Electric Chain Hoist

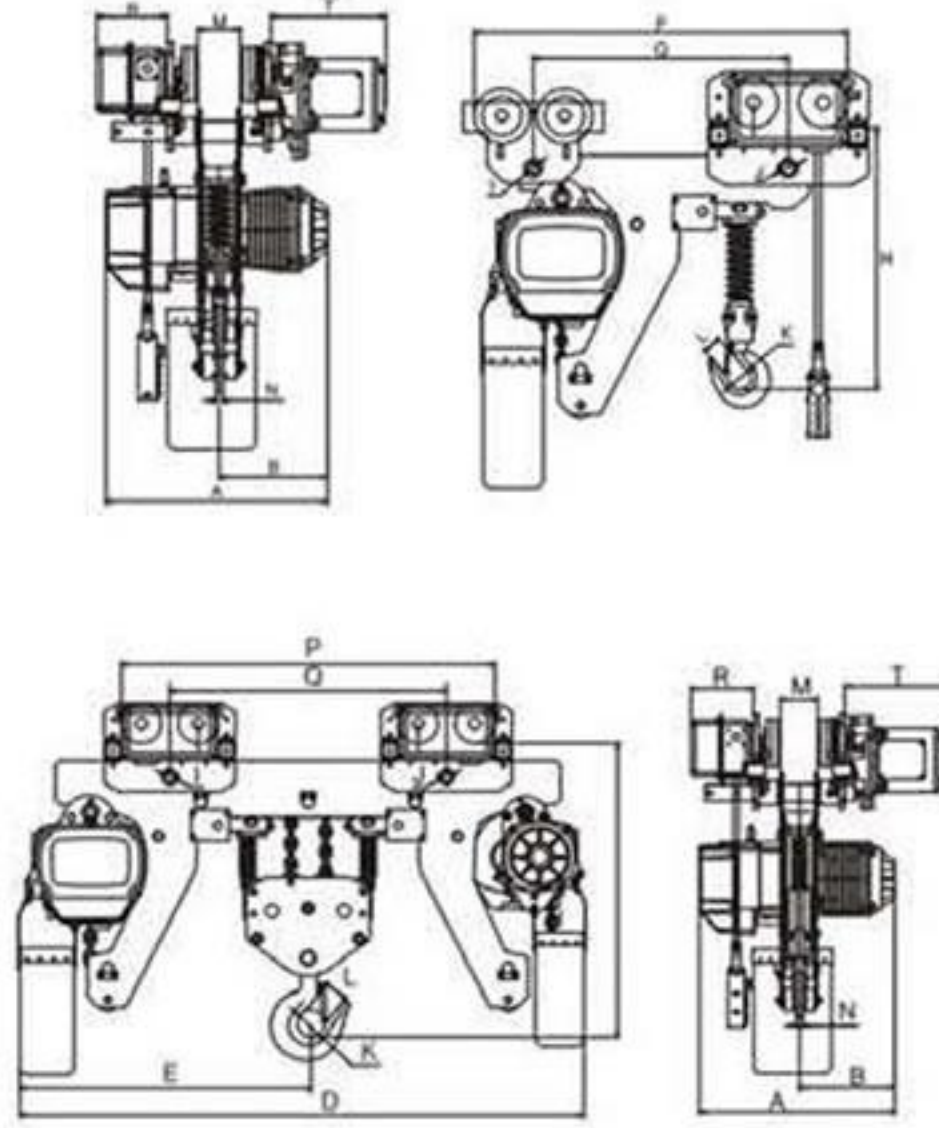

Size Specification 尺寸规格表

单速/双速 Single Speed/Dual Speed

Type 型号	H	A	B	D	E	I	J	K	L	M	N	P	Q	R	T
WBH-00501SL	440	460	230	/	/	φ31	φ31	φ35	25	52	17	585	400	142	231
WBH-01001SL	480	520	260	/	/	φ31	φ31	φ40	31	56	22	630	445	142	231
WBH-01501SL	570	615	295	/	/	φ31	φ36	φ47	38	66	30	720	505	142	231
WBH-02001SL	570	615	295	/	/	φ31	φ36	φ47	38	66	30	720	505	142	231
WBH-02002SL	535	520	260	/	/	φ31	φ36	φ47	38	56	30	665	445	142	231
WBH-02501SL	640	615	295	/	/	φ36	φ43	φ58	47	73	36	775	526	142	231
WBH-03001SL	640	615	295	/	/	φ36	φ43	φ58	47	73	36	775	526	142	231
WBH-03002SL	685	615	295	/	/	φ36	φ43	φ58	47	66	36	750	503	142	231
WBH-05002SL	740	615	295	/	/	φ43	φ54	φ60	48	73	43	825	541	142	231
WBH-07503SL	890	615	295	/	/	φ43	φ54	φ60	48	73	55	1020	730	142	231
WBH-10004SL	880	630	315	1640	820	φ54	φ54	φ85	80	85	55	926	630	142	231
WBH-00501DL	440	545	260	/	/	φ31	φ31	φ35	25	52	17	585	400	142	231
WBH-01001DL	480	582	280	/	/	φ31	φ31	φ40	31	56	22	630	445	142	231
WBH-01501DL	570	670	313	/	/	φ31	φ36	φ47	38	66	30	720	505	142	231
WBH-02001DL	570	670	313	/	/	φ31	φ36	φ47	38	66	30	720	505	142	231
WBH-02002DL	535	582	280	/	/	φ31	φ36	φ47	38	56	30	665	445	142	231
WBH-02501DL	640	670	313	/	/	φ36	φ43	φ58	47	73	36	775	526	142	231
WBH-03001DL	640	670	313	/	/	φ36	φ43	φ58	47	73	36	775	526	142	231
WBH-03002DL	685	670	313	/	/	φ36	φ43	φ58	47	66	36	750	503	142	231
WBH-05002DL	740	670	313	/	/	φ43	φ54	φ60	48	73	43	825	541	142	231
WBH-07503DL	890	670	313	/	/	φ43	φ54	φ60	48	73	55	1020	730	142	231
WBH-10004DL	880	670	388	1640	820	φ54	φ54	φ85	80	85	55	926	630	142	231

电动小车

Electric Trolley

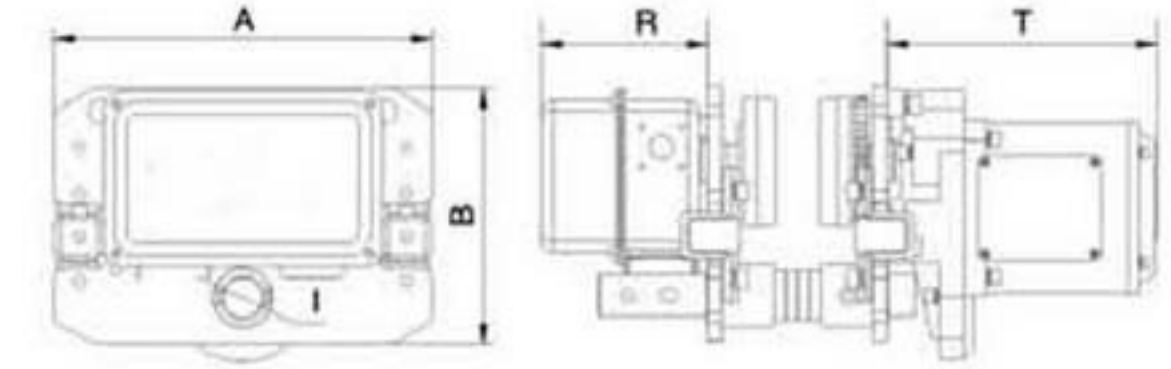

Size Specification 尺寸规格表

Type 型号	ET-005	ET-010	ET-020	ET-030	ET-050	ET-075	ET-100
Capacity 荷重(t)	0.5	1	2	3	5	7.5	10
Unit 单位(mm)	A	315	315	325	340	400	500
	B	212	212	220	250	291	370
	R	142	142	142	142	142	142
	T	231	231	231	231	231	231
	I	φ31	φ31	φ36	φ43	φ54	φ54
Speed 速度 50Hz(m/min)	11/21	11/21	11/21	11/21	11/21	11/21	11/21
Motor 马达(kW)	0.4	0.4	0.4	0.75	0.75	0.75	0.75
Minimum Turning Radius 最小回转半径(m)	0.8	0.8	0.8	1.0	1.8	1.8	2.5
I-Beam 工字钢梁轨道(mm)	52-153	52-153	82-178	100-178	100-178	100-178	150-220

手动小车

Manual Trolley

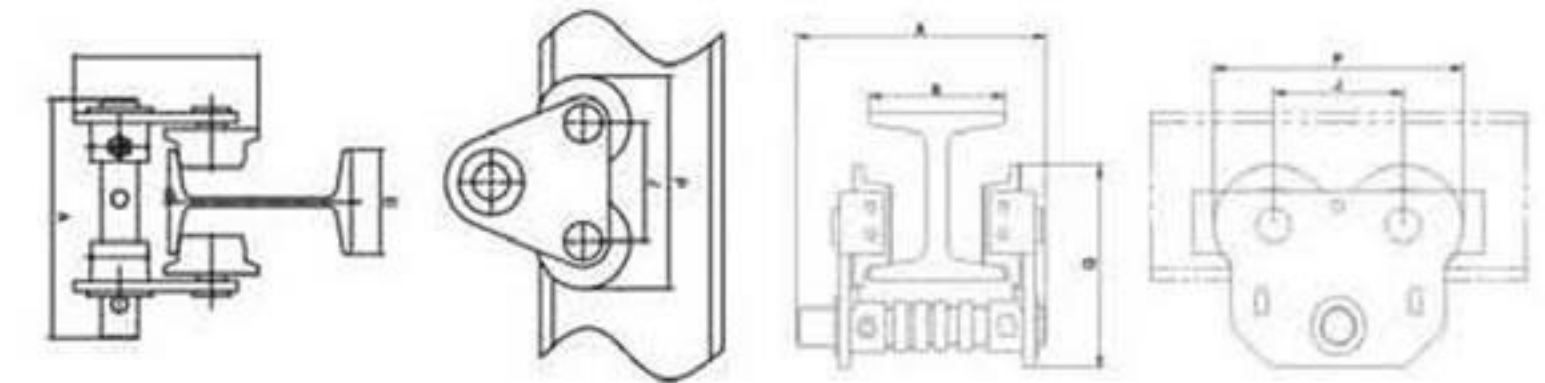

Size Specification 尺寸规格表

Type 型号	MT-005	MT-010	MT-020	MT-030	MT-050	
Capacity 荷重(t)	0.5	1	2	3	5	
Unit 单位(mm)	A	200	200	218	275	275
	G	170	170	205	236	280
	J	115	115	138	157	178
	E	50-102	50-102	68-130	82-153	82-153
	P	221	221	265	305	332
Minimum Turning Radius 最小回转半径(m)	0.6	0.6	1.0	1.0	1.2	

葫芦配件 Hoist Accessories

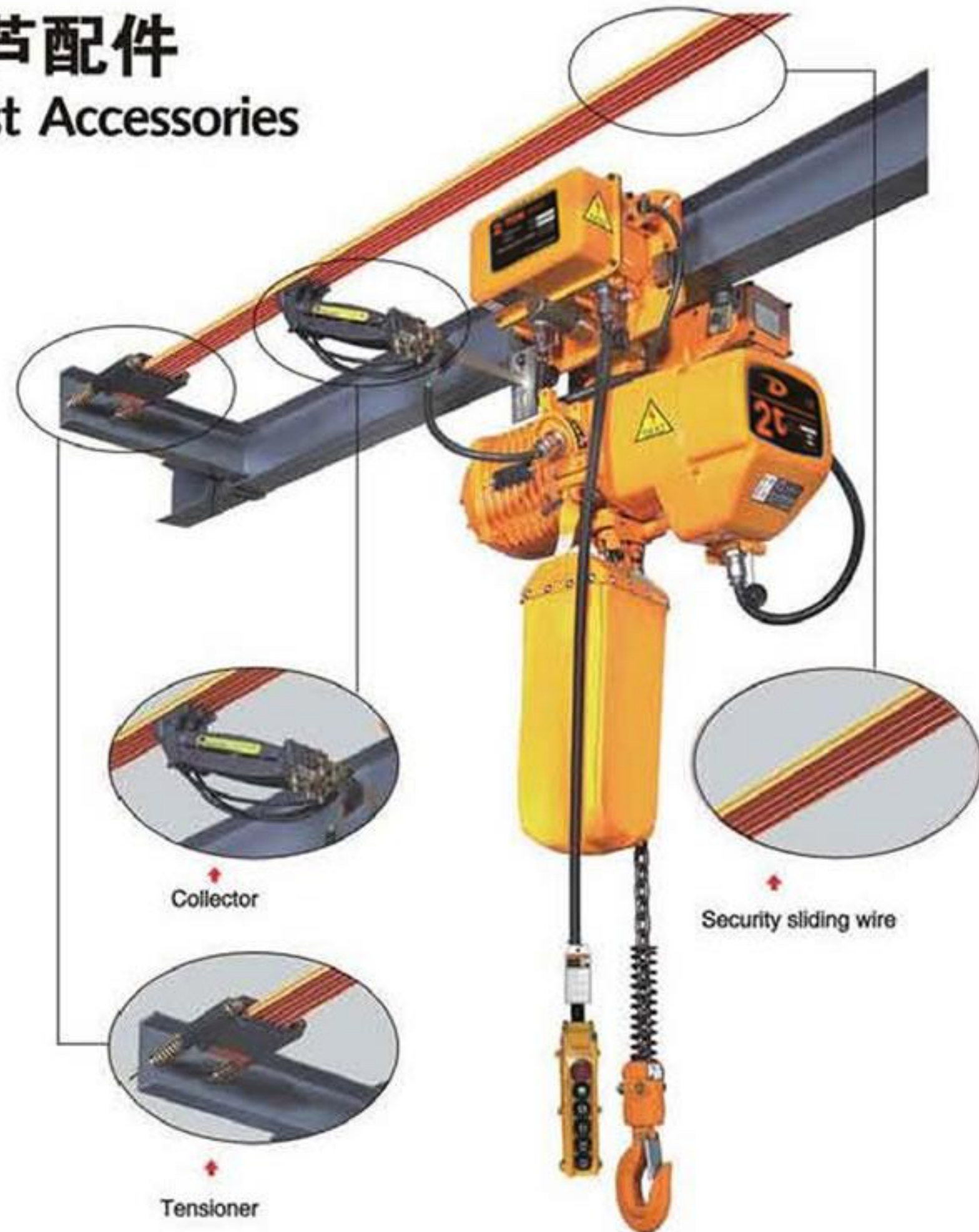

Collector

Security sliding wire

Tensioner

工程案例 Customers



世界500强-意大利CMC100t工程
Fortune 500-ITA CMC 100t Project



中马集团生产流水线
ZOMAX Group Production Line



陕汽骏通车辆厂汽车翻转系统工程
SAJT Auto. Flipping System Project



上海建工90米高度起升工程
SCG-90m Lifting Project



悬臂吊
Jib Crane



单梁起重机
Single Girder Crane



双梁起重机
Dual Girder Crane



↑ Wireless remote control for single speed.



↑ Wireless remote control for dual speed



↑ Chain bag